

Overview

TBL series - familiar to many by the name of dual-sinker liquid level relays - is a breakthrough product that is completely different from the conventional liquid level relays applying the mechanism of floats within liquid. Conventional liquid level relays require 2 float switches for upper and lower limit controls of the liquid surface. Kasuga's dual-sinker liquid level relay allows both upper and lower limit controls of the liquid surface using a single unit.

Features

- Operates regardless of the liquid resistivity. Not only in seawater and sewage water, the relay can also be used in liquids that do not conduct electricity (such as distilled water, oil, etc.).
- Control range can be set and changed by varying the length of the handling rope.
- Allows remote installation of control devices and alarm devices as the relay is unaffected by external induction or static electricity between electric wires.
- Protection Code IP33 (rainproof type)

Caution

TBL 12FC (for oil) is not explosion-proof. Observe laws and regulations for use.



Standard specifications

Item	Specification
Rating	1NO+NC 250V AC 1.5A (Coil load)
Control range	0.18 to 10m
Water tank pressure	1 atm
Tolerance	500,000 times or more mechanically 500,000 times or more electrically
Standard	Electrical Appliance and Material Safety Law (compliant product)

Product list

TBL (standard set)

TBL 12 is a set of main unit (TBLP2), sinkers (TBLS) and hanging ropes (TBLR).  
TBL 12FC is a set of main unit (TBLF2), sinkers (TBLC208) and hanging ropes (TBLR).

Exterior	Type name	Main unit [Material]	Sinker [Material]	Hanging rope [Material]	Application Specific gravity range	Approximate weight (g)
	TBL 12	TBLP2 [Polycarbonate]	TBLS [Hard vinyl chloride]	TBLR (3m) [Tetron]	Treatment water, sewage water, seawater, etc. (0.85 to 1.05)	930
	TBL 12B	TBLP2B [Polycarbonate] (Micro-load compatible)				
	TBL 12 FC	TBLF2 [Aluminum casting]	TBLC208 [Copper]		Heavy oil, light oil, kerosene oil, etc. (0.70 to 0.90)	1310
	TBL 12 FCB	TBLF2B [Aluminum casting] (Micro-load compatible)				

Main unit

Application	Material	Usage temperature	Description	Type name	Approximate weight (g)
For water	Polycarbonate	-10 to +50°C	—	TBLP2	325
			Micro-load compatible(5V DC 1mA)	TBLP2B	
For oil, warm water	Aluminum casting	-10 to +80°C	—	TBLF2	670
			Micro-load compatible(5V DC 1mA)	TBLF2B	

Basic type list

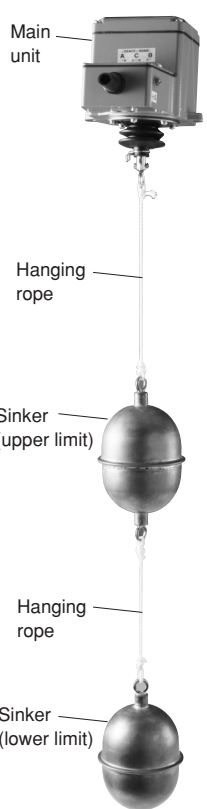
	TBL 12 (for water)	TBL 12FC (for oil)
Application	Treatment water, sewage water, seawater, etc.	Heavy oil, light oil, kerosene oil
Applied specific gravity range	0.85 to 1.05	0.7 to 0.9
Material	Main unit	TBLP2: polycarbonate
	Sinker	TBLS: hard vinyl chloride
	Hanging rope	TBLR: tetron 3m
Exterior		

Dual-Sinker Liquid Level Relay

TBL Series

Sinker

Series name	Material	Specific gravity	Usage temperature (°C)	Application	Type name	Approximate weight (g)
TBLS series (for upper/lower limit operation)	Hard vinyl chloride	0.85 to 1.05	-10 to 50	TBL12 standard accessories, for water	<b>TBLS</b>	500 (2 units)
		1.00 to 1.064		For special specific gravity	<b>TBLS2103</b>	512 (2 units)
		1.05 to 1.15		(Standard upper limit sinker + special lower limit sinker)	<b>TBLS211</b>	528 (2 units)
		1.15 to 1.25			<b>TBLS212</b>	551 (2 units)
		1.25 to 1.35			<b>TBLS213</b>	574 (2 units)
		1.35 to 1.45			<b>TBLS214</b>	597 (2 units)
		1.45 to 1.55			<b>TBLS215</b>	620 (2 units)
TBLC1 series (for alarm operation)	Copper	0.70 to	-10 to 80	Upper limit alarm, for water/oil	<b>TBLC108</b>	500 (1 unit)
	Stainless steel	0.85 to 1.05		Lower limit alarm, for water	<b>TBLC1SL10</b>	
		0.70 to		Upper limit alarm, for water/oil	<b>TBLC1SU08</b>	
		0.85 to 1.05		Lower limit alarm, 1.5 inch pipe, for water	<b>TBLC1SX10</b>	480 (1 unit)
TBLC2 series (for upper/lower limit operation)	Copper	0.70 to 0.90	-10 to 80	TLB12FC standard accessories, for oil	<b>TBLC208</b>	500 (2 units)
	Stainless steel	0.85 to 1.05		For water	<b>TBLC2S10</b>	
		0.70 to 0.90		For oil	<b>TBLC2S08</b>	
		1.45 to 1.55		For special specific gravity	<b>TBLC2S15</b>	620 (2 units)
		0.85 to 1.05		2 inch pipe, for water	<b>TBLC2SX10</b>	500 (2 units)
		0.70 to 0.90		2 inch pipe, for oil	<b>TBLC2SX08</b>	
		1.20 to 1.30		Special specific gravity	<b>TBLC2S125</b>	

Remark: Sinker includes hanging rope (TBLR 3m).

Hanging rope

Material	Application	Sales unit	Type unit	Approximate weight (g)	Remarks
Tetron	For water/oil	10m $\phi$ 3	<b>TBLR</b>	—	Avoid freezing when using in an environment with ambient temperature of 0°C or less. When using TBLK, make sure the total length is 1m or less. (Using length of 1m or more may affect operation)
		200m $\phi$ 3	<b>TBLR200M</b>	—	
Brass (cut-out chain) + ring (stainless)		1m	<b>TBLK</b>	11	

Option

Use when installing main unit to 2-inch pipe coupling.

Product name	Type name	Approximate weight (g)
Adapter	<b>TBLA2</b>	110

TBLA2 (adapter)

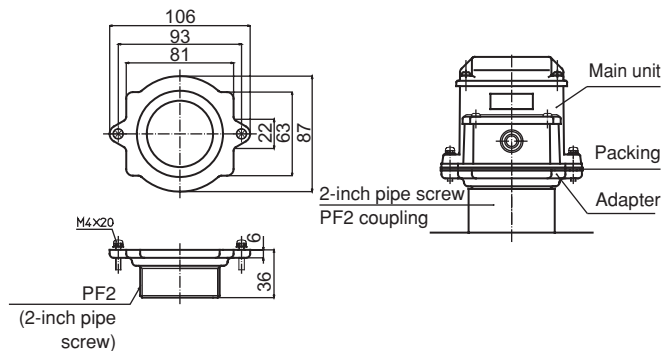

TBLC108 (upper-limit alarm copper sinker)

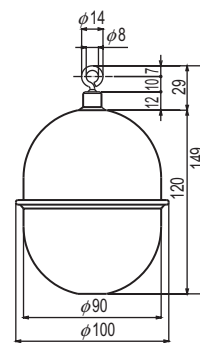

External dimensions (Unit:mm)

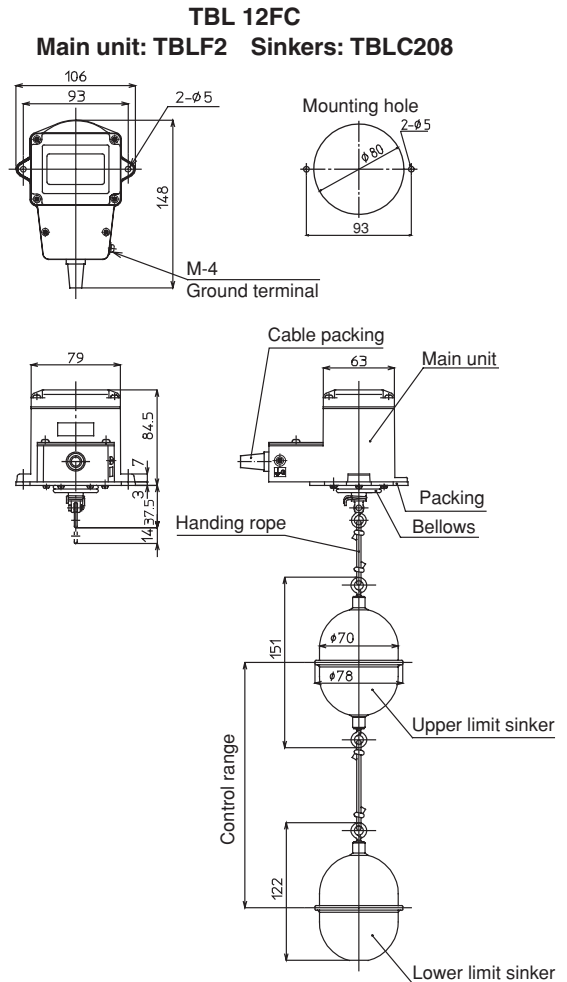
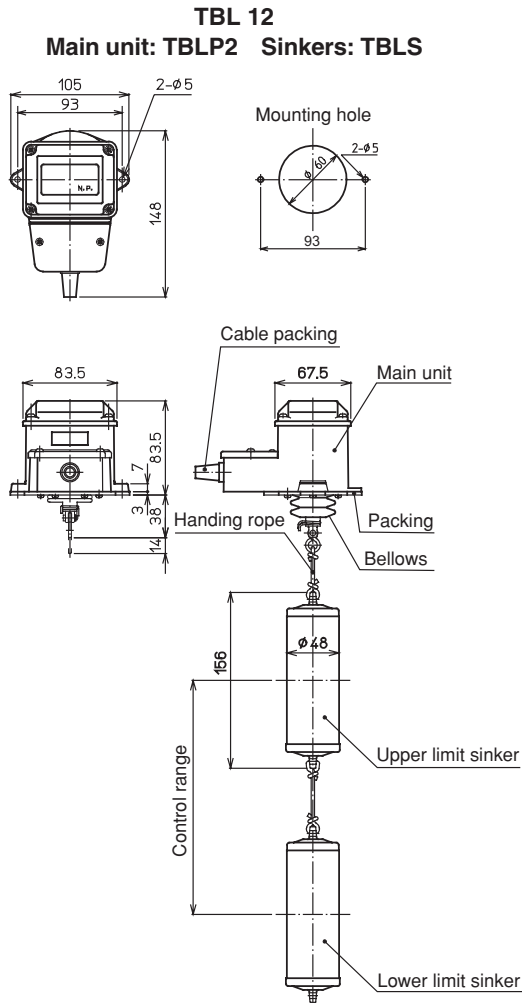

Operation

The micro-switch within the main unit opens/closes when the sinkers move up/down by detecting the liquid surface changes. Operation flow of automatic water-supply operation using the dual-sinker liquid level relay is explained below.

- ① When the water surface rises to the middle of the upper limit sinker.
- ② When the water surface is in the middle of the upper and lower limit sinkers.
- ③ When the water surface drops to the middle of the lower limit sinker.
- ④ When the water surface is in the middle of the upper and lower limit sinkers.

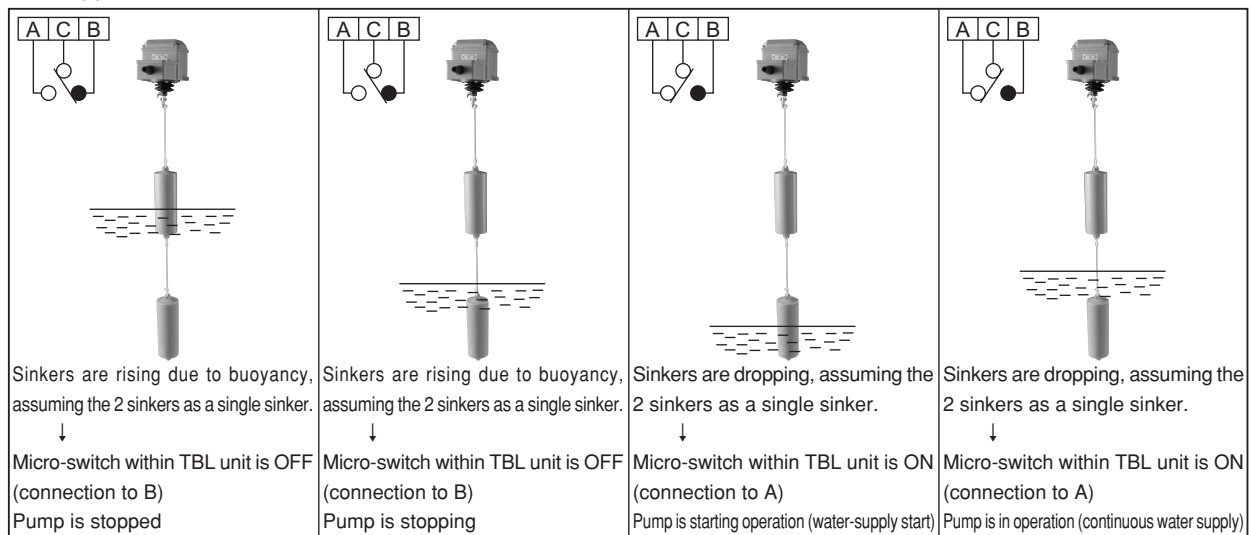

⑤ Operations ① to ④ are repeated by opening/closing of the micro-switch within the liquid level relay to perform automatic water-supply operation. To perform water-discharge operation, replace terminals A and B of the liquid level relay.

Connection diagrams

Standard automatic water-supply/water-discharge operation

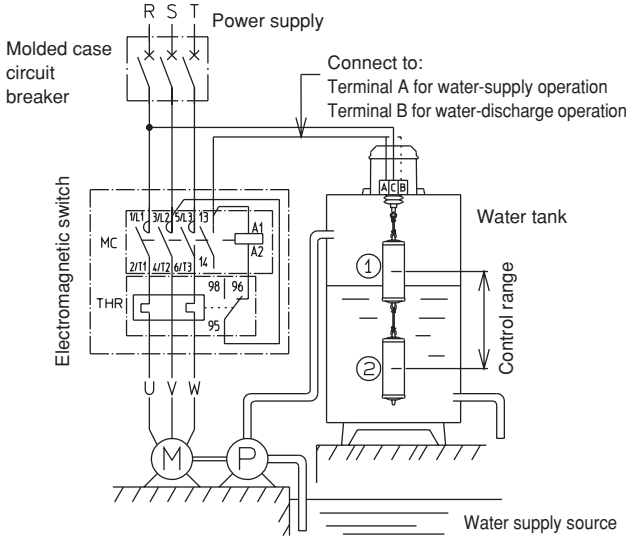

Overview of operation

- Water-supply operation  
The pump stops when the water surface rises near the middle of upper limit sinker ①, and the pump operates when the water surface drops near the middle of lower limit sinker ②. This operation is repeated.
- Water-discharge operation  
The pump operates when the water surface rises near the middle of upper limit sinker ①, and the pump stops when the water surface drops near the middle of lower limit sinker ②. This operation is repeated.

Use terminals A to C for water-supply operation and terminals B to C for water-discharge operation to connect to the electromagnetic switch as shown in the diagram.

Caution: Make sure to ground when using an aluminum casing unit.

Automatic water-supply operation combined with pump idle prevention

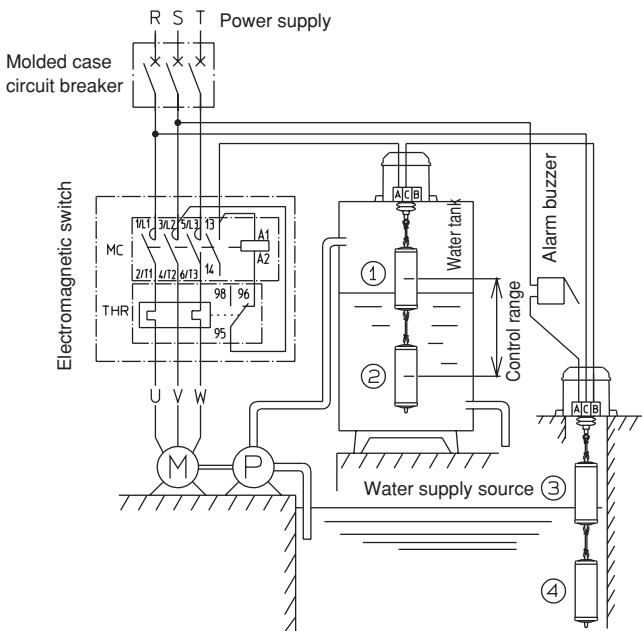

Overview of operation

- The pump stops and alarm sounds when the water surface of the water supply source drops near the middle of lower limit sinker ④. Normal water-supply operation resumes when the water surface rises near the middle of upper limit sinker ③. In addition, a copper bell can be used for the alarm relay as shown below.

Upper limit alarm using alarm copper bell

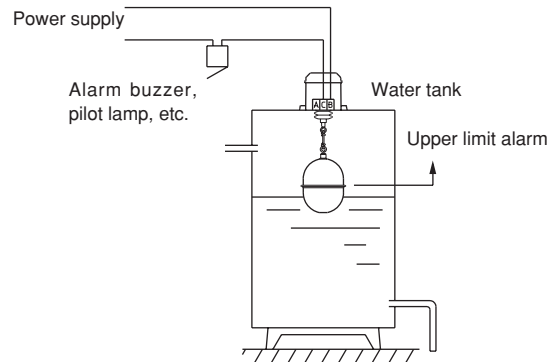

Cautions concerning usage

- ① Tying the hanging rope  
Always use the supplied tetron ropes for the sinkers and tie using the method shown on the right. The length from the middle of the upper limit sinker to the middle of the lower limit sinker will be the control range.
- ② Installation location of main unit  
Set the main unit so that it is level to the tank exterior. Do not install where there is corrosive gas, combustible gas or extreme humidity.
- ③ TBL12 and TBL12FC set sinkers must be used as a set. Do not use just 1 sinker.
- ④ TBL12FC (for oil) is not explosion-proof. Observe laws and regulation for use.
- ⑤ Malfunction may occur when foreign substances adhere to the detection sinkers. Perform inspection once a month and remove any adhered foreign substances.

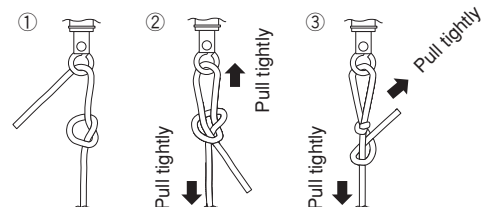

Melting the knot using flame is effective for preventing loosening.

- ⑥ Some liquids and environments may affect hanging ropes, etc., causing malfunction as a result. Perform inspection once every 3 months and replace with new TBL12 (FC) in the case exterior deterioration or damage is noticed.

Selection of sinkers

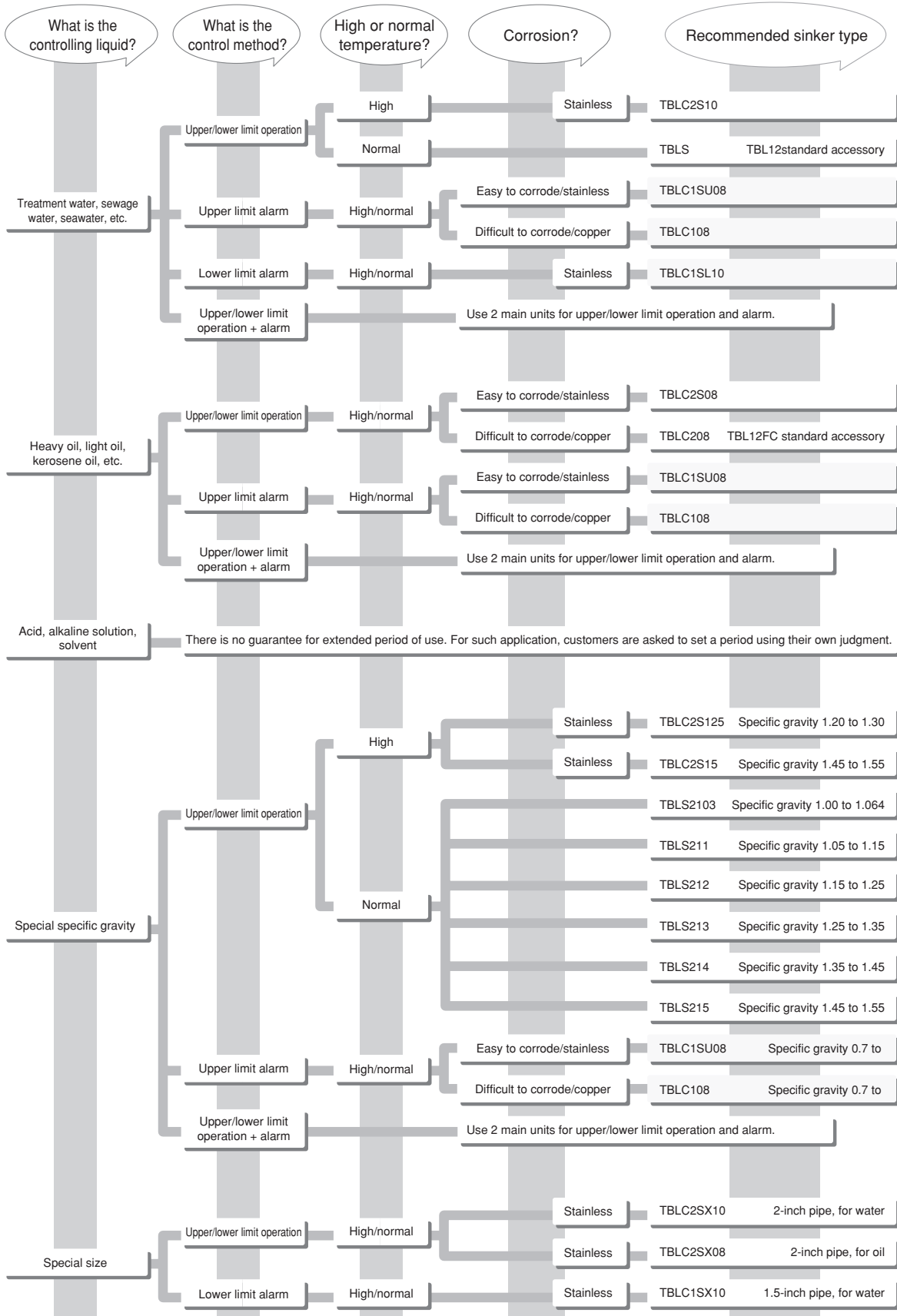

Remarks:

1. This product is not explosion-proof. Observe laws and regulations for use.
2. Liquids of high viscosity may affect the operation of the unit.
3. High-temperature model may be used up to 80°C and normal-temperature model may be used up to 50°C.
4. Anticorrosive performance is realized by stainless steel (SUS304).